

VESTFROST



FZ 107/158/211/244/321/133/189/247/284/368 C

Instructions for use



Thank you for purchasing your new freezer from Vestfrost. Please note that these instructions apply to all chest freezers in the FZ range. Illustrations and fittings may therefore not necessarily correspond exactly to your model.

Warning

As the refrigerant used in this appliance is a flammable gas (Isobutane R600a), special care must be taken to prevent damage to the refrigerant circuit and piping during transport and installation.

If damage does occur, avoid sparks or naked flame in the vicinity of the appliance, ensure that the room is well ventilated, disconnect the power supply, and contact your supplier.

The unit must only be serviced by qualified technicians from an approved service centre.

Old appliances

Old refrigerators and freezers are often fitted with complicated latches that can only be opened from the outside. If you have one of these old units stored away somewhere, or if you scrap one, remember to destroy the latch first in order to prevent children from being exposed to danger by getting locked inside the unit.

Disposal

This appliance contains recyclable materials. Before disposing of the unit, detach the plug from the cable and remove the freezer lid. If the lid is left on, the appliance is highly dangerous for children at play.

Environmental regulations on disposal must also be observed. When disposing of the

appliance you should contact your local authority technical department who will inform you of how collection and recycling of such units take place in your area.

Before use

Before operating your new appliance, please read the following instructions carefully as they contain important information on safety, installation, operation and maintenance. Keep the instructions for future reference.

On receipt, check to ensure that the appliance has not been damaged during transport. Transport damage should be reported to the local distributor before the appliance is put to use.

Remove the packaging. Clean the inside of the cabinet using warm water with a mild, perfume-free detergent. Rinse with clean water and dry thoroughly (see cleaning instructions). Use a soft cloth.

If the appliance has been stored in cold surroundings (colder than +5°C), it must be allowed to stabilise in an upright position for at least an hour before being switched on.

If during transport the appliance has been stood on end, it must be allowed to stabilise in normal position for approx. 12 hours before being switched on.

Contents

Get to know your chest freezer.....	3
Installation and start-up.....	4
Electrical connection.....	5
Operation and function.....	6
Use.....	8
Defrosting.....	9
Cleaning and maintenance.....	10
Fault finding.....	11
Warranty, spare parts and service..	12

Get to know your chest freezer

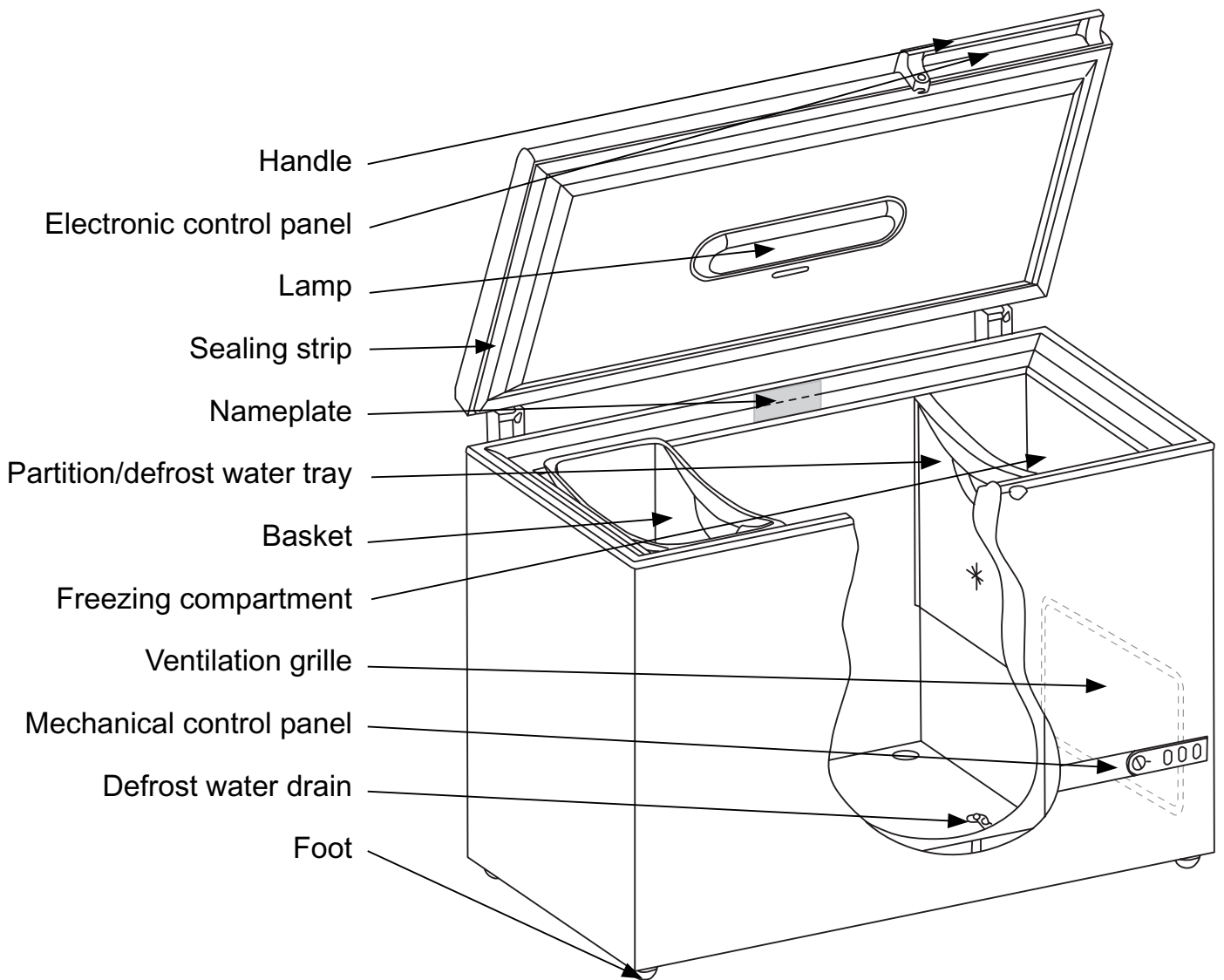

fig. 1

Installation and start-up

Placement

For safety and operational reasons, the appliance must not be installed outdoors.

The appliance should be placed on a stable, level surface in a dry, well-ventilated room (max. 75% relative air humidity).

Never place the appliance close to sources of heat such as cookers or radiators, and avoid placing it in direct sunlight.

Room temperature

The climate class is stated on the nameplate (see fig. 1 on page 3 and fig. 10 on page 12). This specifies the optimum room temperature.

Climate class	Optimum room temperature
SN	+10 °C to +32 °C
N	+16 °C to +32 °C
ST	+18 °C to +38 °C
T	+18 °C to +43 °C

If the room temperature is sub zero, the appliance will not function correctly.

Ventilation

It is important that the appliance be well ventilated and that air can circulate unhindered above, below and around it. Figure 2 illustrates how the necessary air circulation can be ensured.

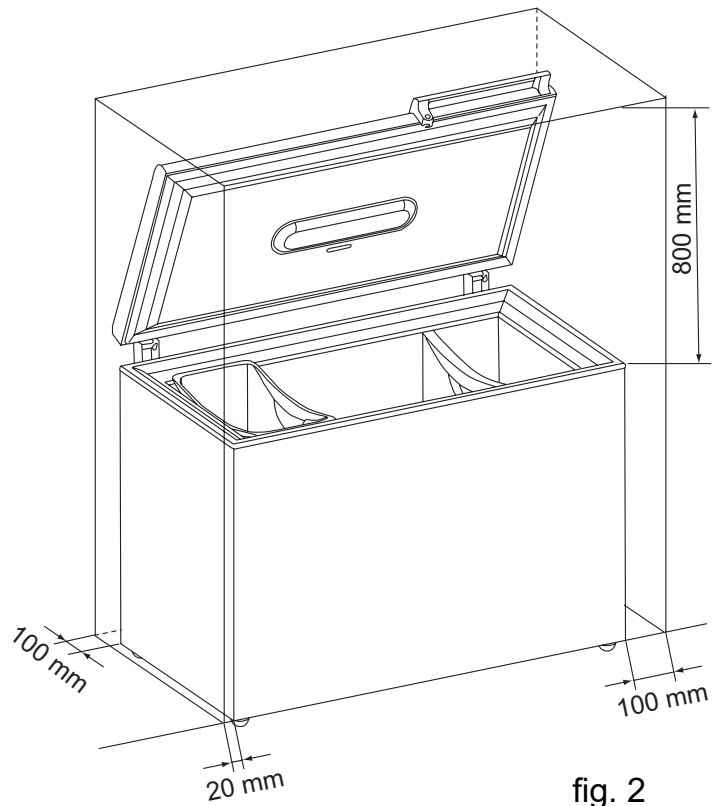

fig. 2

There must be at least 15 mm clearance between the base of the appliance and the floor.

IMPORTANT! There must be free access to the ventilation grille (fig. 3).

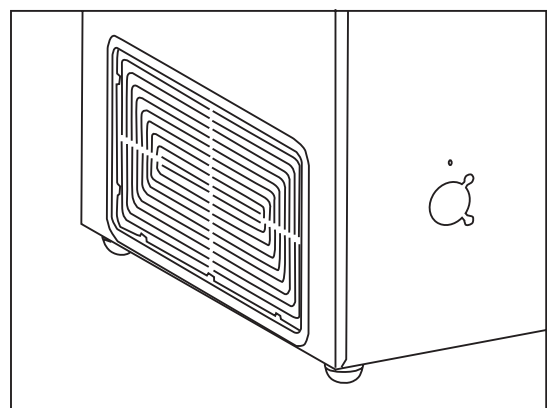

fig. 3

Electrical connection

The appliance is intended for connection to alternating current. The required voltage (V) and frequency (Hz) are stated on the nameplate on the rear of the appliance. Power must be connected via an independent wall socket outlet.

If the mains lead has been damaged, it must be replaced with a corresponding type supplied by the manufacturer or an approved service centre.

Technical data

This appliance complies with CE marking regulations, directives and standards. Low Voltage Directive 73/23/EEC.

EMC Directive 89/336/EEC.

Council Directive 92/75/EEC on the energy labelling of household appliances as subsequently amended by 94/2/EC and 2003/66/EC.

Directive 96/57/EC on energy efficiency requirements, and subsequent amendments.

Operation and function

FZ chest freezers are equipped with either mechanical controls (fig. 4) or electronic controls (fig. 5).

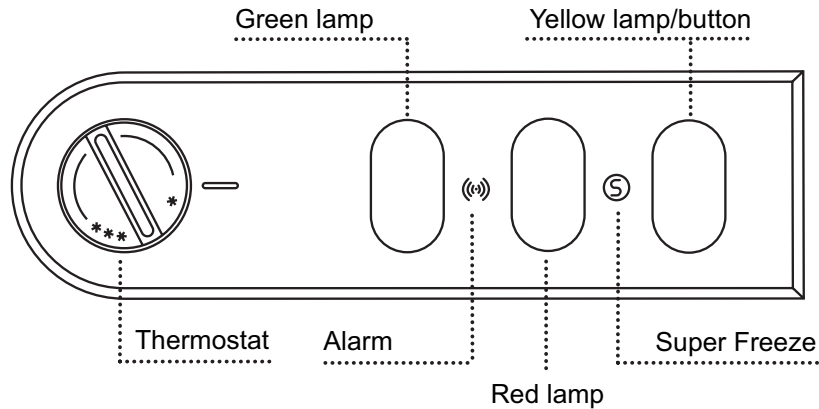

fig. 4

Mechanical controls

In addition to a thermostat knob, the control panel contains two control lamps and a button (fig. 4).

The green lamp is lit when power is correctly supplied.

The red lamp is lit when the temperature inside the freezer is higher than the thermostat setting.

The yellow lamp is lit when Super Freeze has been activated (see Super Freeze).

Acoustic alarm

An acoustic alarm is activated when the red lamp is lit. The alarm is switched off when the yellow button is activated.

Starting up

Connect the appliance to the socket outlet. The green lamp lights up to indicate that power is supplied. The red lamp on the control panel will also light up to indicate that the temperature inside the freezer is not yet sufficiently low. To accelerate cooling, activate Super Freeze.

Temperature setting

The temperature is set by turning the thermostat knob from * (least cold) to *** (coldest). It is recommended that a coin be used to turn the knob. The more the thermostat knob is turned towards ***, the lower the temperature. To test whether the setting is correct, measure the temperature of the uppermost item in the centre of the freezer. It must be no warmer than -18°C .

Super Freeze

If more than 3 kg of fresh items are to be frozen, proceed as follows:

1. Press the Super Freeze button (the yellow lamp lights up). The freezer then operates at maximum capacity (the compressor runs continuously).
2. Activate Super Freeze 24 hours before placing fresh items in the freezer.
3. After placing fresh items in the freezer, leave Super Freeze on for a further 24 hours.
4. Then press the Super Freeze button again (the yellow lamp goes off).

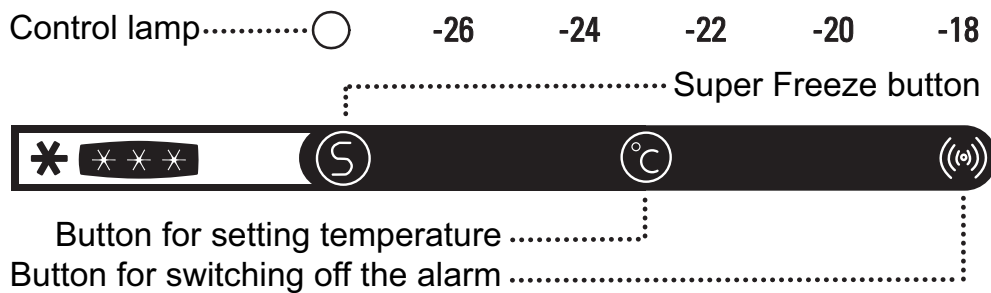



fig. 5

The electronic controls have the following functions:

- Temperature setting
- Temperature display
- Super Freeze
- Acoustic and visual alarms

Starting up

Connect the power supply. The electronic controls run a self-test program and various temperatures are shown briefly on the display (fig. 5). The yellow and red lamps flash and the acoustic alarm is activated. The yellow lamp then goes off. Press  to switch off the acoustic alarm.

The appliance is factory set to maintain -18°C . This is the ideal temperature for long-term, energy-saving storage of frozen items. Only set a lower temperature if items are often placed in, or removed from, the freezer or if the room temperature is unusually high.

Temperature setting

The temperature can be set from -28°C to -18°C . Press the temperature display button  to show the current temperature setting on the display. Continue to press the button until the desired temperature is displayed. The temperature setting last shown is saved automatically.

Super Freeze

Before freezing large quantities of fresh food, it is recommended that the Super Freeze function be activated.

To do so, press the Super Freeze button . The control lamp flashes yellow to indicate that the Super Freeze function is switched on. The freezer then operates at maximum capacity (the compressor runs continuously).

When Super Freeze is activated, the automatic temperature control (i.e. the thermostat) is deactivated and the temperature falls to a lower level. Activate Super Freeze up to 24 hours before placing fresh items in the freezer. After 26 hours, Super Freeze is automatically switched off. Remember to switch Super Freeze off and then back on again when fresh items are placed in the freezer.

High-temperature alarm

The red alarm lamp on the display begins flashing if the actual temperature in the freezer rises more than 4°C above the temperature setting. The acoustic alarm is activated simultaneously. If the temperature drops again, the visual and acoustic alarms remain active. Press the alarm button  to switch off the acoustic alarm. The red alarm lamp continues to flash as long as the temperature inside the freezer is too high.

Use

Freezer

The appliance is a four-star freezer approved for freezing and storing frozen items of food.

Freezing

To keep food at its best, items must be frozen to -18°C as quickly as possible.

The freezing capacity of the freezer is stated on the nameplate in kg/24 hours (see fig. 1 on page 3 and fig. 10 on page 16).

Activating the Super Freeze function reduces freezer temperature to -25°C .

If items weighing 3 kg or more are to be frozen, the Super Freeze button should be activated about 24 hours in advance.

To freeze smaller quantities, it is sufficient to activate Super Freeze just a couple of hours in advance, or even at the same time as items are placed in the freezer.

There is no need to use Super Freeze when pre-frozen items are placed in the freezer or when small, single items are involved.

Only freeze high-quality fresh produce. Meat, poultry, fish, vegetables, fruit, dairy products and ready-made meals are suitable for freezing. Items with a high water content, e.g. lettuce, radishes, grapes, apples, pears and cucumbers, are not suitable for freezing.

Pack items to be frozen in airtight containers, freezer bags or similar. Freeze items in suitable portions. Do not freeze vegetables or meat in portions larger than 2.5 kg. Keep packages dry to prevent them from freezing together. To ensure rapid freezing, make sure, as far as possible, that items placed in the freezer are not touching. Ensure that there is as little air in the packages as possible to prevent the surfaces of the items from drying out.

Items to be frozen should be placed in the freezing compartment or evenly distributed along the inner walls of the freezer.

Always remember to write the date, content and quantity on the packages before placing them in the freezer. It is a good idea to group items within the freezer. Keep vegetables in one place, meat in another, and so on.

There must be at least 5 mm clearance between items stored in the freezer and the lid.

Items stored in the baskets are highly visible and easily accessible (fig. 6).

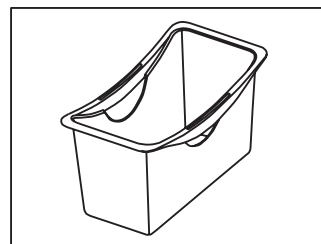

fig. 6

Thawing

Frozen vegetables and fruit require no thawing before use and can be immersed in boiling water direct from the freezer.

To thaw meat, it is advisable to take it out of the freezer the day before it is to be used and place it in a refrigerator to defrost. This ensures the best hygiene and maintains quality as much as possible.

Note:

Glass bottles or cans containing carbonated (fizzy) drinks must never be placed in the freezer as they may explode.

Defrosting

The items stored and the humidity of the air gradually cause frost and ice to form in the freezer. A thin layer of frost or ice does not affect freezer performance, but the thicker the layer, the higher the energy consumption. Loose frost can be removed using the plastic scraper located in the partition.

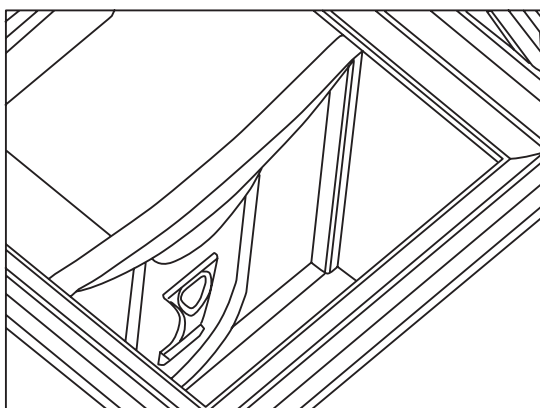

fig. 7

Never use electrical apparatus or sharp implements as these may damage the inside of the appliance.

When the layer of frost and ice exceeds 4-5 mm the freezer should be completely defrosted. It is recommended that defrosting be performed when there are no or only a few items stored in the freezer.

Proceed as follows:

1. Press the Super Freeze button 4-5 hours before defrosting. This lowers the temperature of the items stored to approx. -25°C , thus prolonging the length of time they remain frozen after having been removed from the freezer (see step 3 below).
2. Disconnect the power supply.
3. Remove the items of food. Place them in a refrigerator or wrap them up to keep them as cold as possible.
4. Keep the freezer lid open.

5. Position the partition under the defrost water drain.
6. Place a bowl of hot (but not boiling) water in the freezer, close the lid and wait approx. 30 minutes before removing loose frost with the plastic scraper.
7. To prevent water from damaging the floor during defrosting, it is advisable to check the defrost water tray from time to time and to cover the floor around the defrost water drain to protect against ice and splashes. When all the frost and ice have melted, clean the inside of the cabinet using water with a mild, perfume-free detergent. Dry the freezer with a soft cloth.
8. Reconnect the power supply. If many items are to be returned to the freezer, activate the Super Freeze button.
9. Return items to the freezer approx. 5 minutes after having switched it on.

Remember to reinsert the stopper in the defrost water drain.

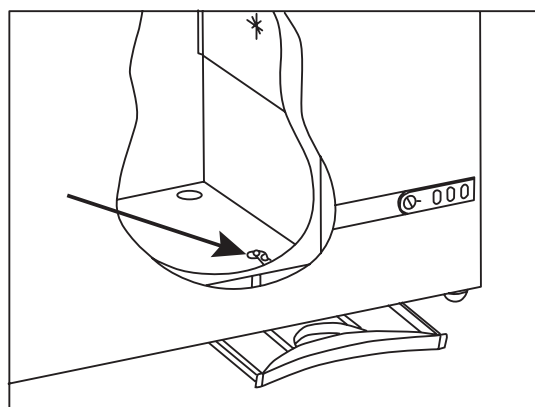

fig. 8

Cleaning and maintenance

Cleaning

Before cleaning, disconnect the power supply and remove all loose fittings.

The cabinet is best cleaned using warm water (max. 85°C) with a little mild, perfume-free detergent. Never use cleaning agents that scour. Use a soft cloth. Rinse with clean water and dry thoroughly. It is important to prevent water from entering the control panel.

The sealing strip around the lid must be cleaned regularly to prevent discolouration and prolong service life. Use clean water. After cleaning the sealing strip, check that it continues to provide a tight seal.

The ventilation grille must be kept free of dust and dirt. Clean it with a vacuum cleaner.

if the appliance is not to be used for any length of time, switch it off, disconnect the power supply, empty it, clean the cabinet and leave the lid open to allow air circulation and prevent smells.

Replacing the bulb

1. Disconnect the power supply by pulling the plug out of the socket.
2. Remove the lamp cover by pressing its upper edge downwards to release it from the two clips (fig. 9).
3. Replace the bulb(s).
4. Refit the cover and reconnect the power supply.

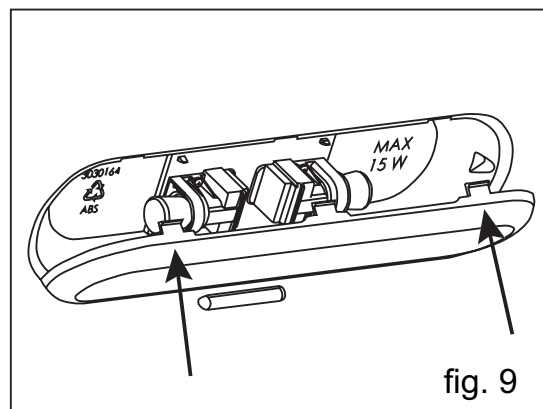

Save energy

- Cool hot food and beverages before placing them in the freezer.
- Thaw frozen items in a refrigerator.
- Keep the lid closed as much as possible.
- Check regularly that the lid closes tightly.
- Position the freezer in a cool (min. 5°C), well-ventilated room.
- Place frozen items in a refrigerator while defrosting the freezer.
- Defrost the freezer before the layer of ice becomes excessively thick.

Fault finding

Fault	Possible cause	Remedy
No control lamps are lit.	<p>The appliance is switched off.</p> <p>Power failure; the fuse is blown; the appliance is not plugged in correctly.</p>	<p>Check the plug and socket.</p> <p>Check that power is connected. Reset the fuse.</p>
Temperature in freezer too high.	<p>The ventilation grille is blocked.</p> <p>The lid is not closed properly.</p> <p>The quantity of items placed in the freezer is greater than the capacity of the appliance.</p> <p>Thick layer of frost and ice.</p> <p>The thermostat is set too high.</p>	<p>Ensure unhindered air circulation.</p> <p>Close the lid and wait a few hours.</p> <p>Wait a few hours.</p> <p>Defrost the freezer.</p> <p>Set the thermostat to a lower temperature.</p>
Temperature in freezer too low.	<p>Super Freeze is activated.</p> <p>The thermostat is set too low.</p> <p>The lid is touching items stored in the freezer.</p>	<p>Switch Super Freeze off.</p> <p>Set the thermostat to a higher temperature.</p> <p>Reposition items inside the freezer and check that the lid closes tightly.</p>
The freezer produces large quantities of frost.	<p>Air humidity in the room is high.</p> <p>Items placed in the freezer are giving off moisture.</p>	<p>Ventilate the room more often or move the freezer to a room with lower humidity.</p> <p>Repack items stored in the freezer.</p>
The lid cannot be opened.	<p>There is underpressure in freezer.</p>	<p>Wait 2-3 minutes until the underpressure has been equalised and try again.</p>
Vibration and unusual noise.	<p>The appliance is not on a level surface.</p> <p>The appliance is not free standing.</p> <p>Baskets or partition are loose.</p>	<p>Position the freezer on a flat, level and stable surface.</p> <p>Move the appliance away from other appliances or pieces of furniture.</p> <p>Check movable fittings and reposition them.</p>

Warranty, spare parts and service

Warranty disclaimer

Faults and damage caused directly or indirectly by incorrect operation, misuse, insufficient maintenance, incorrect building-in, installation or mains connection, fire, accident, lightening, voltage variation or other electrical interference, including defective fuses or faults in mains installations, or repairs performed by others than service centres approved by Vestfrost, and any other faults and damage that the manufacturer can substantiate are caused by reasons other than manufacturing or material faults are not covered by the warranty.

Transport damage discovered by the buyer is primarily a matter to be settled between the buyer and the distributor, i.e. the distributor must ensure that such complaints are resolved to the buyer's satisfaction.

Before calling for technical assistance, please check whether you are able to rectify the fault yourself (see Fault finding). If your request for assistance is unwarranted, e.g. if the appliance has failed as a result of a blown fuse or incorrect operation, you will be charged the costs incurred by your call for technical assistance.

Spare parts

When ordering spare parts, please state the type, serial and production numbers of your appliance (see fig. 1 on page 3 and fig. 10). This information is given on the nameplate on the rear of the appliance. The nameplate contains various technical information, including type and serial numbers.

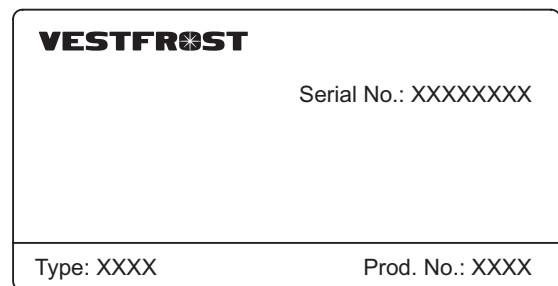

fig. 10

Note: Always use approved service centres when your appliance is to be repaired or replaced!

Service

Vestfrost has local service centres all over the country who specialise in Vestfrost products. Here you can obtain fixed prices and professional help for all repairs. Find your local service centre at www.vestfrost.dk or contact your local distributor.